

NEO-DYN[®]

MODEL 162P

ADJUSTABLE DIFFERENTIAL PRESSURE SWITCHES;

FOR EXPLOSIVE ATMOSPHERES

INSTALLATION AND
OPERATION MANUAL



ENGINEERED FOR LIFE

Manual No. 610-0016 Rev D
Neo-Dyn
28150 Industry Drive
Valencia, CA 91355
Tel: (661) 295-4000
Fax: (661) 294-1750
World Wide Web: www.neodyn.com
©Copyright 2002
ITT Industries

Important Information

The product warranty applicable to this ITT Neo-Dyn[®] instrument is as stated on page 15 of this manual.

Should any after-delivery problems arise, please contact ITT Neo-Dyn's Customer Service using the information above. Our normal business hours are weekdays, 7:00 am to 3:30 PM, Pacific Time.

Before installing this Pressure Switch, become familiar with the installation and adjustment instructions in Chapters 2 and 3.

WARNING Indicates a hazard which can cause severe personal injury, death, or substantial property damage if the warning is ignored.

CAUTION Indicates a hazard which will or can cause minor personal injury or property damage if the caution is ignored.

NOTE Indicates additional information about a particular item necessary to the operation of the unit.

SPECIAL CONDITIONS FOR SAFE USE The Electrical Snap Switch Assemblies shall be installed such that the equipment wiring is protected from mechanical damage by the use of metal conduit or a method providing equivalent protection. The equipment wiring must not be subjected to tension or torque. If it is to be terminated within a potentially explosive atmosphere, a suitably certified termination facility must be used.

This document contains proprietary information, which is the property of Neo-Dyn, a unit of ITT Industries. This document may not be reproduced, either in part or in full, without the consent of ITT Industries.

TABLE OF CONTENTS

	PAGE
CHAPTER 1 INTRODUCTION	1
CUSTOMER SERVICE.....	3
OTHER CONFIGURATIONS.....	3
CHAPTER 2 INSTALLATION	4
MOUNTING	4
PROCESS CONNECTIONS	5
PROCESS MEDIA	6
POTENTIALLY EXPLOSIVE ATMOSPHERES (HAZARDOUS LOCATIONS).....	6
ELECTRICAL CONNECTIONS	7
CHAPTER 3 ADJUSTMENTS AFTER INSTALLATION	8
SETPOINT ADJUSTMENT	8
CHAPTER 4 TROUBLESHOOTING	9
CHAPTER 5 SPECIFICATIONS	11
STANDARD	11
OPTIONS.....	14
WARRANTY INFORMATION.....	15

CHAPTER

1

INTRODUCTION

The Neo-Dyn® Enclosure 6N Switches described in this manual are weather and explosion-proof, electromechanical sensing devices designed for a wide range of applications in pneumatic and hydraulic systems up to 5,000 psig, and for use in Zone 1 Potentially Explosive Atmospheres (Division 1 hazardous locations).

Wetted materials include a polyimide (Kapton) sensing diaphragm, nitrile O-ring, corrosion resistant steel (CRES) and helical springs of either zinc plated steel music wire or CRES. Wetted material 1 switches also contain aluminum alloy materials.

Setpoint adjustments are easily made through the adjustable range by turning an external adjustment nut shown in figure 1.

The standard configuration of these switches will switch up to 11 amp at 125 or 250 VAC, 5 amp resistive at 28 VDC, or 0.5 amp resistive at 125 VDC. When ordered with M Option, the switch is rated for currents to one amp, but its bifurcated gold contacts will reliably switch currents in the milliamper and microampere ranges.

These switches have CE Mark, weatherproof enclosures with IP 66 ingress protection and meet the requirements of NEMA 3, 3R, 3S, 4, 4X and 13. The electrical subassemblies are approved by Underwriters Laboratories, FM, CSA International and ATEX.

Figure 1: Models 162P:
Adjustable Differential Pressure Switches

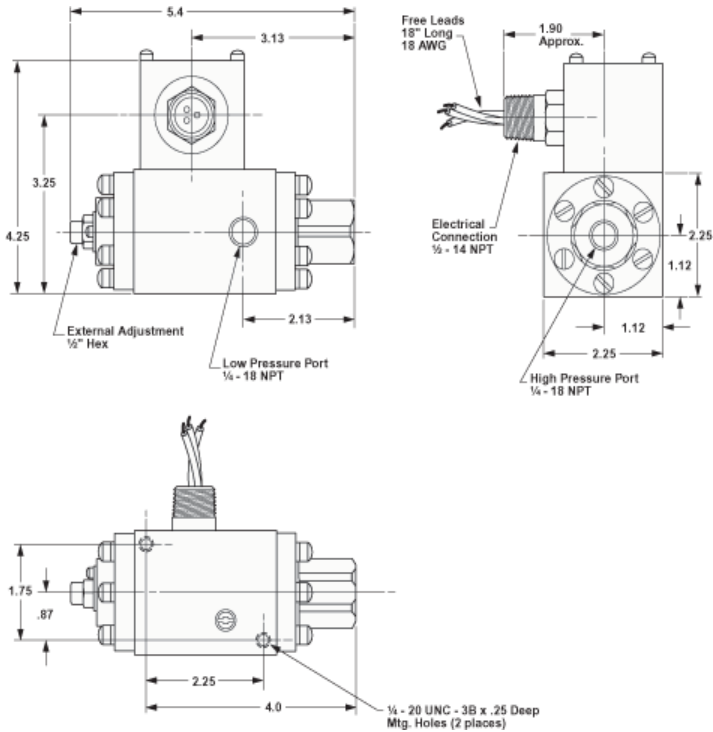

Dimensions are in inches

Chapter 5 on page 11 contains complete specifications for these Adjustable Pressure Switches.

CUSTOMER SERVICE

If you have any questions about these Differential Pressure Switches that are not covered in this manual, you can contact Neo-Dyn or our representatives in several ways.

The Neo-Dyn customer service phone number is (661) 295-4000. Our customer service department is open from 7:00 am to 3:30 p.m. Pacific Time.

Our Internet site is www.neodyn.com; it includes lists of sales representatives and distributors.

OTHER CONFIGURATIONS

WARNING The models described in this manual are also available in special and factory-set configurations. For these units, follow the installation and operating instructions herein, **except adhere to the pressure and electrical limits marked on the units.**

CHAPTER

2

INSTALLATION

Installation of these Neo-Dyn® Enclosure 6N pressure switches is straightforward. However, they must be installed by a qualified electrician, in compliance with all local and national electrical codes.

***WARNING* Electrical Hazard**

***WARNING* Do not make electrical connections while power is on.**

***WARNING* Always check for multiple circuits.**

***WARNING* Always make sure grounding is adequate.**

MOUNTING

The Pressure Switch can be mounted directly to the process connections if there is no significant vibration and the fluid lines are capable of supporting the weight. It can also be attached to a flat surface, such as a wall or panel, using ¼-20 UNC screws into the mounting holes shown in Figure 1. The holes are .25 inches deep. Do not over tighten the screws.

PROCESS CONNECTIONS

The process connections are 1/4" - 18 NPT female.

When installing the Pressure Switch, always:

- Make sure that the unit and your system have matching threads.
- Use the wrench flats provided.
- Seal all joints with pipe joint sealing compound.

CAUTION Avoid excessive torque on all threaded connections.

WARNING **Do not exceed the marked Maximum Operating Pressure in normal operation.**

The marked Proof Pressure is provided to give the maximum allowable pressure without causing permanent damage to the pressure switch in the event of an over-pressure condition. Set pressure relief/safety valves below this setting.

PROCESS MEDIA

Process media must be compatible with the wetted materials listed in Chapter 5 starting on page 12. Compatibility is defined by an “A” rating in the Chemical Resistance Guide for Metals and Alloys, the Chemical Resistance Guide for Plastics, and the Chemical Resistance Guide for Elastomers, all published by Compass Publications, and available from the National Association of Corrosion Engineers (NACE), Houston, Texas; telephone 281 228-6200.

POTENTIALLY EXPLOSIVE ATMOSPHERES (HAZARDOUS LOCATIONS)

Suitable for Zone 1, EEx d IIC explosive atmospheres, in accordance with Potentially Explosive Atmospheres Directive 94/9/EC (ATEX)

Suitable for Division 1; Class 1, Groups A, B, C and D; Class II, Groups E, F and G hazardous locations, in accordance with the National Electric Code (NEC), and applicable UL, FM and CSA specifications.

ELECTRICAL CONNECTIONS

Figure 2. Form C and CC schematics shown below the decreasing setpoint.

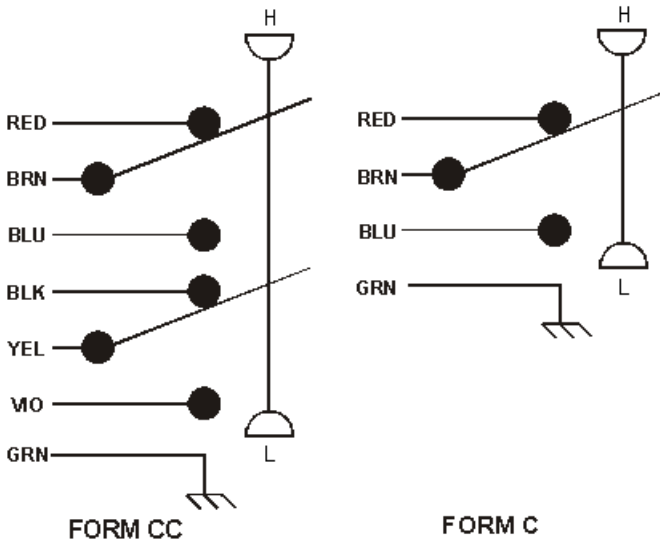

18 AWG free leads 18 in (46 cm) long are standard, with a green wire grounded to the case. 72 inch (183 cm) leads are available as R Option, and other lead lengths may be ordered as special configurations. The leads are intended for installation in conduit capable of withstanding possible explosion pressures, and the leads are factory sealed.

WARNING All field wiring must comply with requirements of the NEC or applicable local or national electrical codes, including wire gauges and insulation temperature ratings. Conduit seals may be required.

CHAPTER

3

ADJUSTMENTS AFTER INSTALLATION

The factory-set setpoint or adjustable setpoint range is marked on the nameplate of the switch. This section describes the adjustments needed after an Adjustable Pressure Switch has been properly installed.

SETPOINT ADJUSTMENT

Disconnect the electrical power. Check for multiple circuits.

1. Check the setpoints per paragraphs 3 and 4 below for precise adjustments.
2. The adjustment nut (See Figure 1) can be rotated with an open-end wrench or similar tool.
3. To check the increasing setpoint of these switches, connect a pressure source and a calibrated differential pressure gauge or transducer to the pressure ports and apply the system pressure to both sides. Slowly apply increasing pressure to the “high side” port until the switch actuates. Actuation can be noted by listening to the audible snap of the Belleville spring, or with an ohmmeter across the appropriate free leads.
4. To check the decreasing setpoint, follow step 3 above, then slowly lower the pressure on the high side and note the value at which the audible snap or an ohmmeter indicates deactuation. Deadband may be calculated if desired by subtracting the decreasing setpoint reading from the increasing setpoint reading.

CHAPTER

4

TROUBLESHOOTING

In-service problems are unlikely, but the following paragraphs suggest ways to verify any problems that might arise:

1. Pressure Switch Leaks

If a leak is suspected, isolate the pressure switch from the rest of the system. Connect the switch and a calibrated pressure gauge downstream from a pressure source and shutoff valve. Apply normal system pressure, isolate the gauge and Pressure Switch from the pressure source with the shutoff valve for at least one minute, and check for leaks as evidenced by a drop in the gauge reading.

If a leak is verified, return the unit for repair. Contact ITT directly, or your local sales representative or distributor (see www.neodyn.com for a contact list).

2. Failure to Switch

If application of pressure 10% greater than the adjusted setpoint fails to produce actuation, first check for contamination in the process connection, and verify that the expected pressure is reaching the sensing diaphragm.

If the Belleville spring can be heard to audibly snap, but an ohmmeter indicates no electrical switching, the cause is probably stuck or burned switch contacts, or the switch element has moved away from the position where it was synchronized with the snap action. Return the unit for repair.

If application of pressure 10% greater than the adjusted setpoint fails to produce an audible snap of the Belleville spring, there is probably a mechanical failure or binding due to contamination. Return the unit for repair.

3. Calibration Shifts

If it is suspected that the setpoints have shifted, recheck them per paragraphs 3 and 4 of Chapter 3. If you verify unstable or drifting setpoints, return the unit for repair.

CHAPTER

5

SPECIFICATIONS

This section shows standard specifications and available options.

STANDARD

Interfaces

Weight: approximately 3 pounds (1.4 kg) each; 4 pounds (1.8 kg) with the H option.

Conduit Connection: ½" - 14 NPT male

Pressure Ports: ¼" – 18 NPT female

Listing Agency Approvals

Switch Subassemblies UL, FM and CSA and SIRA (ATEX) listed

CE Mark; Conforms with Council Directive: 94/9/EC and 97/23/EC.

Part Number

The part number contains information about which configurations and options are included in your Adjustable Pressure Switch. To determine the pressure range, electrical rating, and options, compare the part number of your unit with the information in Figure 3 below and the following tables.

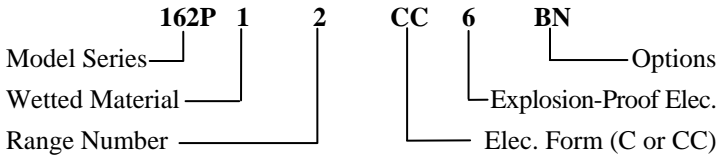

Figure 3. Part Number Breakdown

NOTE Part number format varies for specials.

Wetted Materials

Table 1	
No	Description
1	Aluminum alloy port, teflon-coated polyimide (Kapton) diaphragm and nitrile O-ring, CRES and zinc plated steel music wire springs
4	UNS S31600 CRES port, teflon coated polyimide diaphragm and nitrile O-ring and CRES springs

Pressure Ratings

Maximum Operating Pressure: 5000 psig (344.7 Bar)

Proof Pressure: 2500 psig (172.4 Bar) high over low or low over high.

Weather Proof Ratings

Ingress protection IP66

Enclosure type 3, 3R, 3S, 4, 4X, 13 (NEMA)

Temperature Ranges for Pressure Media

Standard (Nitrile O-rings): -40°C (-40°F) to +121°C (+250°F)

C Option (EPR O-rings): -40°C (-40°F) to +121°C (+250°F)

B Option (Viton O-rings): -26°C (-15°F) to +121°C (+250°F)

Electrical and Ambient Temperature Ratings

Minimum ambient temperature is -40 °C (-40 °F), except with B Option O-rings it is -26°C (-15°F)

Form C6N (SPDT):

11 amp @ 125 or 250 VAC to +75 °C (+167 °F) max, T5;

11 amp @ 125 or 250 VAC to +60 °C (+140 °F) max, T6;

5 amp @ 125 or 250 VAC 5; 3 amp inductive @ 28 VDC; .5 amp resistive, .04 amp inductive @ 125 VDC to +70 °C (+158 °F) max, T6.

Form CC6N (DPDT):

11 amp @ 125 or 250 VAC to +65 °C (+149 °F) max, T4A;

11 amp @ 125 or 250 VAC to +45 °C (+113 °F) max, T6;

5 amp @ 125 or 250 VAC; 5 amp resistive , 3 amp inductive @ 28 VDC; .5 amp resistive, .04 amp inductive @ 125 VDC to +70 °C (+158 °F) max, T6.

Form C6MN or CC6MN (SPDT or DPDT with M Option):

1 amp @ 125 VAC to +70 °C (+158 °F) max. T6

OPTIONS

The available options for standard switches are listed below. These options can be combined; every included option will be indicated in the part number of the unit.

Table 2	
Option	Description
A	Epoxy-painted exterior
B	Viton O-Ring - Refer to Wetted Materials
C	EPR O-Ring - Refer to Wetted Materials
H	Stainless Steel housing (standard with Wetted material 4)
M	Gold Electrical Contacts For Extremely Low Current Applications
N	CE mark
R	72 inch (183 cm) leads

WARRANTY INFORMATION

A. Warranty:

ITT Industries (ITT) warrants that at the time of shipment, the products manufactured by ITT Neo-Dyn and sold hereunder, will be free from defects in material and workmanship and will conform to the specifications furnished or approved by ITT.

B. Warranty Adjustment:

If any defect within this warranty appears, the Buyer shall notify ITT immediately.

ITT agrees to repair or furnish a replacement for, but not install, any product which, within one (1) year from the date of shipment by ITT shall, upon test and examination by ITT, prove defective within the above warranty.

No product will be accepted for return or replacement without the written authorization of ITT. Upon such authorization, and in accordance with instructions by ITT, the product will be returned with shipping charges prepaid by the Buyer. Replacements made under this warranty will be shipped prepaid.

C. Exclusion from Warranty:

THE FOREGOING WARRANTY IS IN LIEU OF AND EXCLUDES ALL OTHER EXPRESSED OR IMPLIED WARRANTIES OF MERCHANTABILITY, OR FITNESS, OR OTHERWISE.

Components manufactured by any supplier other than ITT shall bear only the warranty made by the manufacturer of that product, and ITT assumes no responsibility for the performance or reliability of the unit as a whole.

In no event shall ITT be liable for indirect, incidental or consequential damages nor shall the liability of ITT arising in connection with any products sold hereunder (whether such liability arises from a claim based on contract, warranty, tort or otherwise) exceed the actual amount paid by Buyer to ITT for the products delivered hereunder.

The warranty does not extend to any product manufactured by ITT, which has been subject to misuse, neglect, accident, improper installation, or to use in violation of instructions furnished by ITT.

The warranty does not extend to or apply to any unit, which has been repaired or altered at any place other than at ITT's factory or service locations, by persons not expressly approved by ITT.

