

NEO-DYN[®]

MODELS 132T AND 132TC
ADJUSTABLE TEMPERATURE SWITCHES,
ENCLOSURE 6N FOR EXPLOSIVE ATMOSPHERES

INSTALLATION AND
OPERATION MANUAL



Manual No. 610-0013 Rev C
Neo-Dyn
28150 Industry Drive
Valencia, CA 91355
Tel: (661) 295-4000
Fax: (661) 294-1750
World Wide Web: www.neodyn.com
©Copyright 2002
ITT Industries

Important Information

The product warranty applicable to this ITT Neo-Dyn[®] instrument is as stated on page 13 of this manual.

Should any after-delivery problems arise, please contact ITT Neo-Dyn's Customer Service using the information above. Our normal business hours are weekdays, 7:00 am to 3:30 PM, Pacific Time.

Before installing this Temperature Switch, become familiar with the installation and adjustment instructions in Chapter 2.

WARNING Indicates a hazard which can cause severe personal injury, death, or substantial property damage if the warning is ignored.

CAUTION Indicates a hazard which will or can cause minor personal injury or property damage if the caution is ignored.

NOTE Indicates additional information about a particular item necessary to the operation of the unit.

SPECIAL CONDITIONS FOR SAFE USE The Electrical Snap Switch Assemblies shall be installed such that the equipment wiring is protected from mechanical damage by the use of metal conduit or a method providing equivalent protection. The equipment wiring must not be subjected to tension or torque. If it is to be terminated within a potentially explosive atmosphere, a suitably certified termination facility must be used.

This document contains proprietary information, which is the property of Neo-Dyn, a unit of ITT Industries. This document may not be reproduced, either in part or in full, without the consent of ITT Industries.

TABLE OF CONTENTS

	PAGE
CHAPTER 1 INTRODUCTION	1
CUSTOMER SERVICE.....	2
OTHER CONFIGURATIONS.....	2
CHAPTER 2 INSTALLATION AND OPERATION.....	3
MOUNTING	3
PROCESS CONNECTION.....	4
ALLOWABLE PRESSURES AND TEMPERATURES	4
PROCESS MEDIA	5
ELECTRICAL CONNECTIONS	6
POTENTIALLY EXPLOSIVE ATMOSPHERES (HAZARDOUS LOCATIONS).....	7
SETPOINT ADJUSTMENT	7
CHAPTER 3 TROUBLESHOOTING	9
CHAPTER 4 SPECIFICATIONS	10
STANDARD	10
OPTIONS	12
WARRANTY INFORMATION	13

CHAPTER

1

INTRODUCTION

The Neo-Dyn[®] Enclosure 6N Temperature Switches described in this manual are weather and explosion-proof, electromechanical sensing devices designed for a wide range of applications in pneumatic and hydraulic systems up to 1500 psig, and for use in Zone 1 Potentially Explosive Atmospheres (Division 1 hazardous locations). Models 132T and 132TC differ in that the temperature sensor of Model 132T is directly attached to the housing, while the sensor of Model 132TC is remotely located at the end of a capillary connection.

Both models use austenitic corrosion-resistant steel (300 series) in the area wetted by the process media. Model 132T has a Teflon seal, and Model 132TC uses a graphite-filled non-asbestos packing.

Setpoint adjustments of both models are easily made through the adjustable range by turning an adjustment nut that is accessed by removing the unit's front cover.

The standard configuration of these switches will switch up to 11 amp at 125 or 250 VAC, 5 amp resistive at 28 VDC, or 0.5 amp resistive at 125 VDC. When ordered with M Option, the switch is rated for currents to one ampere, but its bifurcated gold contacts will reliably switch currents in the milliamper and microampere ranges.

These switches have CE Mark; and the internal switching elements are recognized components by both UL and CSA. The weatherproof enclosures are rated for IP66 ingress protection, and they also meet the requirements of NEMA 3, 3R, 3S, 4, 4X and 13. The electrical subassemblies are listed by UL and CSA.

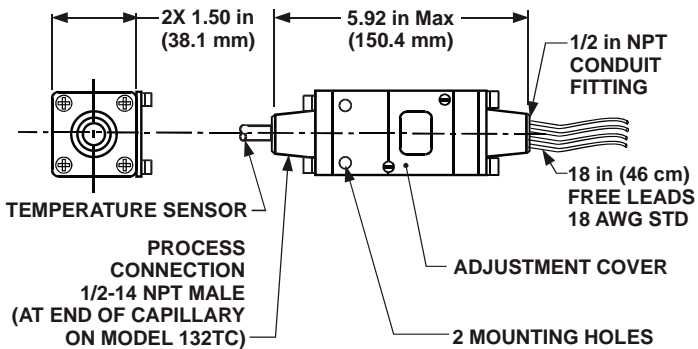

Figure 1: Models 132T and 132TC Enclosure 6N Adjustable Temperature Switches for Explosion Proof Applications

Chapter 4 on page 10 contains complete specifications.

CUSTOMER SERVICE

If you have any questions about these Temperature Switches that are not covered in this manual, you can contact Neo-Dyn or our representatives in several ways.

The Neo-Dyn customer service phone number is (661) 295-4000. Our customer service department is open from 7:00 am to 3:30 p.m. Pacific Time.

Our Internet site is www.neodyn.com; it includes lists of sales representatives and distributors.

OTHER CONFIGURATIONS

WARNING The models described in this manual are also available in special and factory-set configurations. For these units, follow the installation and operating instructions herein, except **adhere to the electrical limits marked on the units.**

CHAPTER

2

INSTALLATION AND OPERATION

Installation of these Neo-Dyn[®] Enclosure 6N temperature switches is straightforward. However, they must be installed by a qualified electrician, in compliance with all local and national electrical codes.

WARNING **Electrical Hazard**

WARNING **Do not make electrical connections while power is on.**

WARNING **Always check for multiple circuits.**

WARNING **Always make sure grounding is adequate.**

MOUNTING

Model 132T Temperature Switches can be mounted directly to the process connection if there is no significant vibration and the fluid lines are capable of supporting the weight, and it can also be attached to a flat surface, such as a wall or panel, using .190 in. diameter (no. 10) or M5 fasteners through the mounting holes that are spaced 1.125 in (28.6 mm) apart. The fastener length should include 1.50 inches (38.1 mm) above the mounting surface.

Model 132TC, which has a remote temperature sensor, must be attached by the mounting holes to a flat surface as described above.

PROCESS CONNECTION

The process connections are:

Model 132T: ½” - 14 NPT male standard. The .25 in. (6.4 mm) dia. temperature probe extends 3.5 in. (89 mm) past the end of the pipe thread.

Model 132TC: ½” - 14 NPT male standard. The .38 in. (9.7 mm) dia. probe extends 4.25 in. (108 mm) min. from the end of the pipe thread, and can be extended an additional 9.5 in. (241 mm). After this length adjustment, torque the gland nut in the pipe fitting to 230 ± 20 in-lb (26.0 ± 2.3 newton-meters).

When installing the Temperature Switch, always:

- Make sure that the unit and your system have matching threads.
- Use the wrench flats provided.
- Seal all joints with pipe-joint sealing compound.

CAUTION Avoid excessive torque on all threaded connections.

ALLOWABLE PRESSURES AND TEMPERATURES

WARNING **Do not exceed the 1500 psig (103.5 bar) Maximum Operating Pressure (System Pressure) in normal operation.**

The 2250 psig (155.1 bar) Proof Pressure is provided to give the maximum allowable pressure without causing permanent damage to the temperature switch in the event of an over-pressure condition. Set pressure relief/safety valves below this setting.

Similarly, the marked Proof Temperature is the maximum temperature the process media could reach in an overtemperature condition without damaging the switch. The gland nut seal on the 132TC model series is NOT designed for pressurized service above 500 °F. As such, a thermowell is required when media temperatures can exceed 500 °F.

PROCESS MEDIA

Process media must be compatible with the wetted materials listed in Chapter 4 on page 11. Compatibility is defined by an “A” rating in the Chemical Resistance Guide for Metals and Alloys and the Chemical Resistance Guide for Plastics, both published by Compass Publications, and available from the National Association of Corrosion Engineers (NACE), Houston, Texas; telephone 281 228-6200.

ELECTRICAL CONNECTIONS

18 AWG free leads, 18 inches (48.3 cm) long are standard. See Figure 2 below for color codes.

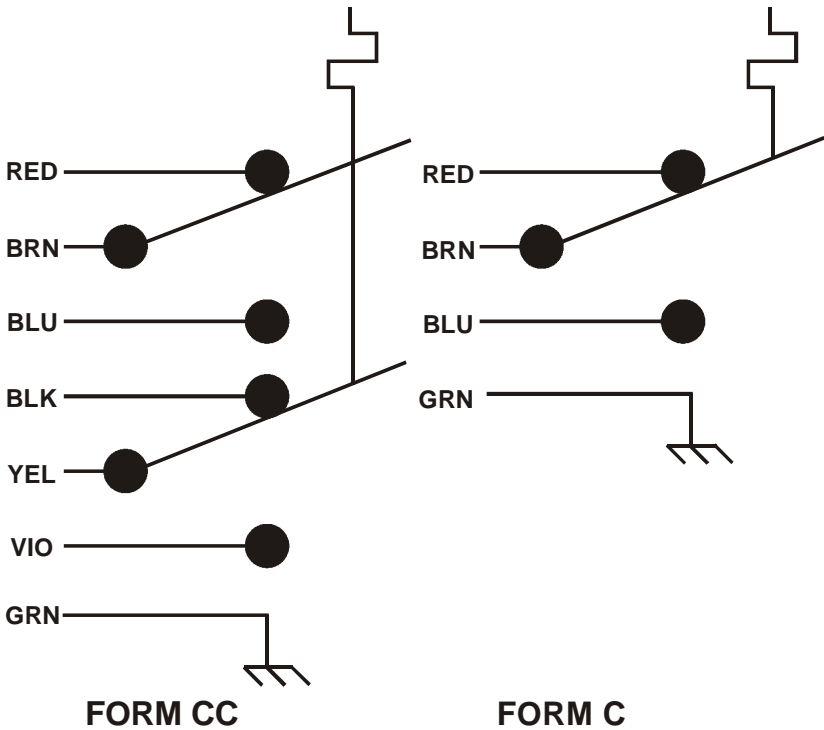

Figure 2. Temperature Switch Schematics Shown Below the Decreasing Setpoint

WARNING All field wiring must comply with requirements of the NEC or applicable local or national electrical codes, including wire gauges and insulation temperature ratings. Conduit seals may be required.

POTENTIALLY EXPLOSIVE ATMOSPHERES (HAZARDOUS LOCATIONS)

Suitable for Zone 1, Eex d IIC explosive atmospheres, in accordance with Potentially Explosive Atmospheres Directive 94/9/EC (ATEX)

Suitable for Division 1; Class 1, Groups A, B, C and D; Class II, Groups E, F and G hazardous locations, in accordance with the National Electric Code (NEC), and applicable UL and CSA specs.

SETPOINT ADJUSTMENT

The factory-set setpoint or adjustable setpoint range is marked on the nameplate of the switch. This section describes the adjustments needed after an Adjustable Temperature Switch has been properly installed.

1. Disconnect the electrical power. Check for multiple circuits.
2. Loosen the screws on the adjustment cover; pivot it out of the way.
3. Rotate the adjustment nut by hand or with a small-shafted screwdriver or similar tool inserted into a slot. The range scale is intended to be used only as an approximate guide; it indicates the increasing setpoint. Make precise final adjustments using the measurements described in para 4 and 5 below.
4. To check the increasing setpoint of a temperature switch, insert the temperature probe into a fluid bath so that the hex is within 3/8 inch (9.5 mm) of the surface, and also insert a calibrated thermometer into the fluid next to the probe. Slowly increase the temperature of the fluid (try not to exceed 5 °C or 9 °F per minute) until actuation is noted by listening to the audible snap of the Belleville spring, or with an ohmmeter across the appropriate free leads
5. If you want to check the decreasing setpoint, slowly decrease the temperature after the switch has actuated and note the value at which the audible snap or an ohmmeter indicates deactuation. Deadband may be calculated if desired by subtracting the decreasing setpoint reading from the increasing setpoint reading.

CAUTION 6. Replace the cover by swinging it back into position over the adjustment window and tightening the screws until the cover is snug against its gasket. Do not overtighten, as this could damage the gasket.

CHAPTER

3

TROUBLESHOOTING

In-service problems are unlikely, but the following paragraphs suggest ways to verify any problems that might arise:

1. Failure to Switch

If application of temperature 10% greater than the adjusted setpoint fails to produce actuation, first check for contamination in the process connection, and verify that the expected temperature is reaching the temperature probe.

If the Belleville spring can be heard to audibly snap, but an ohmmeter indicates no electrical switching, the cause is probably stuck or burned switch contacts, or the switch element has moved away from the position where it was synchronized with the snap action. Return the unit for repair. Contact ITT directly, or your local sales representative or distributor (see www.neodyn.com for a contact list).

If application of temperature 10% greater than the adjusted setpoint fails to produce an audible snap of the Belleville spring, there is probably a mechanical failure or binding. Return the unit for repair.

2. Calibration Shifts

If it is suspected that the setpoints have shifted, recheck them per paragraphs 4 and 5 of Chapter 2. If you verify unstable or drifting setpoints, return the unit for repair.

CHAPTER

4

SPECIFICATIONS

This section shows standard specifications and available options.

STANDARD

Interfaces

Model 132T weighs approximately 20 ounces (0.6 kg) each with an aluminum-alloy body, while Model 132TC weighs approximately 28 ounces (0.8 kg).

Process and Conduit Connections: ½" - 14 NPT male

Part Number

The part number contains information about which configurations and options are included in your Adjustable Temperature Switch. To determine the sensing range, electrical rating, and options, compare the part number of your unit with the information in Figure 3 below and the following tables.

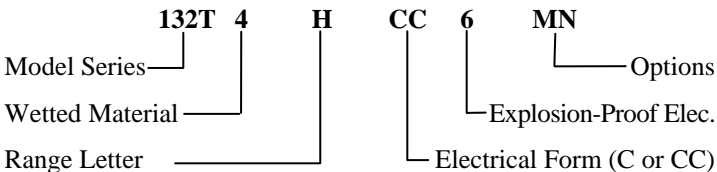

Figure 3. Part Number Breakdown

NOTE Part number format varies for specials.

Wetted Materials

Table 1	
No	Description
4	300-series CRES with teflon seal (Model 132T)
5	300-series CRES with graphite-filled non-asbestos packing (Model 132TC)

Pressure Ratings

Maximum Operating Pressure: 1500 psig (103.5 bar)

Proof Pressure: 2250 psig (155.1 bar)

Electrical and Ambient Temperature Ratings

Minimum ambient temperature is -40 °C (-40 °F)

Form C6N (SPDT):

11 amp @ 125 or 250 VAC to +75 °C (+167 °F) max, T5;

11 amp @ 125 or 250 VAC to +60 °C (+140 °F) max, T6;

5 amp @ 125 or 250 VAC 5; amp resistive , 3 amp inductive @ 28 VDC; .5 amp resistive, .04 amp inductive @ 125 VDC to +70 °C (+158 °F) max, T6.

Form CC6N (DPDT):

11 amp @ 125 or 250 VAC to +65 °C (+149 °F) max, T4A;

11 amp @ 125 or 250 VAC to +45 °C (+113 °F) max, T6;

5 amp @ 125 or 250 VAC; 5 amp resistive , 3 amp inductive @ 28 VDC; .5 amp resistive, .04 amp inductive @ 125 VDC to +75 °C (+167 °F) max, T6.

Form C6MN or CC6MN (SPDT or DPDT with M Option):

1 amp @ 125 VAC to +70 °C (+158 °F) max. T6

Weather Proof Ratings:

Ingress protection IP66

Enclosure type 3, 3R, 3S, 4, 4X, 13 (NEMA)

Listing Agency Approvals

CE Mark All models

Switch Subassemblies UL, CSA, FM,
and SIRA (ATEX & IECEX) listed

OPTIONS

The available options for standard switches are listed below. These options can be combined; every included option will be indicated in the part number of the unit.

Table 2		
Option	Description	Available on Model
A	Epoxy-painted exterior	132T, 132TC
M	Gold Electrical Contacts For Extremely Low Current Applications	132T, 132TC
R	72 inch (183 cm) electrical free leads	132T, 132TC
X	CE mark	132T, 132TC

WARRANTY INFORMATION

A. Warranty:

ITT Industries (ITT) warrants that at the time of shipment, the products manufactured by ITT Neo-Dyn and sold hereunder, will be free from defects in material and workmanship and will conform to the specifications furnished or approved by ITT.

B. Warranty Adjustment:

If any defect within this warranty appears, the Buyer shall notify ITT immediately.

ITT agrees to repair or furnish a replacement for, but not install, any product which, within one (1) year from the date of shipment by ITT shall, upon test and examination by ITT, prove defective within the above warranty.

No product will be accepted for return or replacement without the written authorization of ITT. Upon such authorization, and in accordance with instructions by ITT, the product will be returned with shipping charges prepaid by the Buyer. Replacements made under this warranty will be shipped prepaid.

C. Exclusion from Warranty:

THE FOREGOING WARRANTY IS IN LIEU OF AND EXCLUDES ALL OTHER EXPRESSED OR IMPLIED WARRANTIES OF MERCHANTABILITY, OR FITNESS, OR OTHERWISE.

Components manufactured by any supplier other than ITT shall bear only the warranty made by the manufacturer of that product, and ITT assumes no responsibility for the performance or reliability of the unit as a whole.

In no event shall ITT be liable for indirect, incidental or consequential damages nor shall the liability of ITT arising in connection with any products sold hereunder (whether such liability arises from a claim based on contract, warranty, tort or otherwise) exceed the actual amount paid by Buyer to ITT for the products delivered hereunder.

The warranty does not extend to any product manufactured by ITT, which has been subject to misuse, neglect, accident, improper installation, or to use in violation of instructions furnished by ITT.

The warranty does not extend to or apply to any unit, which has been repaired or altered at any place other than at ITT's factory or service locations, by persons not expressly approved by ITT.

