

NEO-DYN®

MODELS 122P, 123P, 130P, 131P, 132P,
181P, 231P, 232P ADJUSTABLE PRESSURE SWITCHES;

MODELS 125P AND 225P
FACTORY-SET PRESSURE SWITCHES;

ENCLOSURE 6N FOR EXPLOSIVE ATMOSPHERES

INSTALLATION AND
OPERATION MANUAL



ITT

Engineered for life

Manual No. 610-0009 Rev D
Neo-Dyn
28150 Industry Drive
Valencia, CA 91355
Tel: (661) 295-4000
Fax: (661) 294-1750
World Wide Web: www.neodyn.com
©Copyright 2002
ITT Industries

Important Information

The product warranty applicable to this ITT Neo-Dyn® instrument is as stated on page 19 of this manual.

Should any after-delivery problems arise, please contact ITT Neo-Dyn's Customer Service using the information above. Our normal business hours are weekdays, 7:00 am to 3:30 PM, Pacific Time.

Before installing this Pressure Switch, become familiar with the installation and adjustment instructions in Chapters 2 and 3.

WARNING Indicates a hazard which can cause severe personal injury, death, or substantial property damage if the warning is ignored.

CAUTION Indicates a hazard which will or can cause minor personal injury or property damage if the caution is ignored.

NOTE Indicates additional information about a particular item necessary to the operation of the unit.

SPECIAL CONDITIONS FOR SAFE USE The Electrical Snap Switch Assemblies shall be installed such that the equipment wiring is protected from mechanical damage by the use of metal conduit or a method providing equivalent protection. The equipment wiring must not be subjected to tension or torque. If it is to be terminated within a potentially explosive atmosphere, a suitably certified termination facility must be used.

This document contains proprietary information, which is the property of Neo-Dyn, a unit of ITT Industries. This document may not be reproduced, either in part or in full, without the consent of ITT Industries.

TABLE OF CONTENTS

	PAGE
CHAPTER 1 INTRODUCTION.....	1
CUSTOMER SERVICE.....	2
OTHER CONFIGURATIONS.....	3
CHAPTER 2 INSTALLATION.....	4
MOUNTING.....	4
PROCESS CONNECTION.....	5
PROCESS MEDIA.....	5
POTENTIALLY EXPLOSIVE ATMOSPHERES (HAZARDOUS LOCATIONS).....	5
ELECTRICAL CONNECTIONS.....	6
CHAPTER 3 ADJUSTMENTS and TROUBLESHOOTING	7
SETPOINT ADJUSTMENT.....	7
TROUBLESHOOTING.....	8
CHAPTER 4 SPECIFICATIONS.....	10
STANDARD.....	10
OPTIONS.....	18
WARRANTY INFORMATION.....	19

CHAPTER

1

INTRODUCTION

The Neo-Dyn® Enclosure 6N Switches described in this manual are weather and explosion-proof, electromechanical sensing devices designed for a wide range of applications in pneumatic and hydraulic systems up to 12,500 psig, and for use in Zone 1 Potentially Explosive Atmospheres (Division 1 hazardous locations). Models 122P, 123P, 125P, 130P, 131P, 132P, 225P, 231P, and 232P are gauge pressure switches, and Model 181P is a vacuum switch.

The most common wetted materials of these pressure and vacuum switches include a polyimide (Kapton) sensing diaphragm, nitrile O-ring, and aluminum alloy or corrosion resistant steel (CRES) pressure port. CRES diaphragms and all-welded constructions are also available on some models for corrosive pressure media.

Setpoints of Model 130P are easily adjusted by turning an adjustment screw located inside the pressure port, while the other adjustable models have an adjustment nut that is accessed by removing the unit's front cover. Models 131P, 181P, and 231P also include a selectable deadband, which can be factory-set. Models 125P and 225P are factory-set tamperproof units.

The standard configuration of these switches will switch up to 11 amp at 125 or 250 VAC, 5 amp resistive at 28 VDC, or 0.5 amp resistive at 125 VDC. When ordered with M Option, the switch is rated for currents to one amp, but its bifurcated gold contacts will reliably switch currents in the milliamper and microampere ranges.

These switches have CE Mark, and they also have weatherproof enclosures with IP 66 ingress protection, and that meet the requirements of NEMA 3, 3R, 3S, 4, 4X and 13. The electrical subassemblies are listed by UL, CSA, FM and SIRA (ATEX).

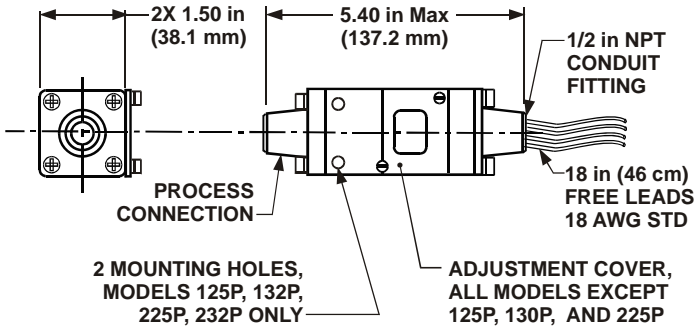

Figure 1: Enclosure 6N
Pressure Switches for Explosive Atmospheres

The standard process connection for each model is described in Chapter 2, and Chapter 4 on page 10 contains complete specifications.

CUSTOMER SERVICE

If you have any questions about these Pressure Switches that are not covered in this manual, you can contact Neo-Dyn or our representatives in several ways.

The Neo-Dyn customer service phone number is (661) 295-4000. Our customer service department is open from 7:00 am to 3:30 p.m. Pacific Time.

Our Internet site is www.neodyn.com; it includes lists of sales representatives and distributors.

OTHER CONFIGURATIONS

WARNING The models described in this manual are also available in special and factory-set configurations. For these units, follow the installation and operating instructions herein, except **adhere to the pressure and electrical limits marked on the units.**

WARNING Models 125P and 225P are tamperproof factory-set units that are installed and operated like models 132P and 232P, but with no provision for setpoint adjustment. **Again, adhere to the pressure and electrical limits marked on the units.**

CHAPTER

2

INSTALLATION

Installation of these Neo-Dyn® Enclosure 6N pressure switches is straightforward. However, they must be installed by a qualified electrician, in compliance with all local and national electrical codes.

***WARNING* Electrical Hazard**

***WARNING* Do not make electrical connections while power is on.**

***WARNING* Always check for multiple circuits.**

***WARNING* Always make sure grounding is adequate.**

MOUNTING

The pressure switch can be mounted directly to the process connection if there is no significant vibration and the fluid lines are capable of supporting the weight; in addition, Models 125P, 132P, 225P, and 232P can also be attached to a flat surface, such as a wall or panel, using .190 in. diameter (no. 10) or M5 fasteners through the mounting holes that are spaced 1.125 in. (28.6 mm) apart. The fastener length should include 1.50 inch (38.1 mm) above the mounting surface.

PROCESS CONNECTION

The process connections are:

Model 130P: ¼" - 18 NPT male standard

Models 131P, 181P, and 231P: combined ¼" - 18 NPT female and ½" - 14 NPT male standard

Models 132P and 232P: ¼" - 18 NPT female standard; ½" - 14 NPT female (G Option) and 7/16-20 SAE (E Option) are available.

Models 125P and 225P: ¼" - 18 NPT female standard

When installing the Pressure Switch, always:

- Make sure that the unit and your system have matching threads.
- Use the wrench flats provided.
- Seal all joints with pipe-joint sealing compound.

CAUTION Avoid excessive torque on all threaded connections.

WARNING **Do not exceed the marked Maximum Operating Pressure in normal operation.**

The marked Proof Pressure is provided to give the maximum allowable pressure for setting pressure relief or safety valves.

PROCESS MEDIA

Process media must be compatible with the wetted materials listed in Chapter 4 on page 17. Compatibility is defined by an "A" rating in the Chemical Resistance Guide for Metals and Alloys, the Chemical Resistance Guide for Plastics, and the Chemical Resistance Guide for Elastomers, all published by Compass Publications, and available from the National Association of Corrosion Engineers (NACE), Houston, Texas; telephone 281 228-6200.

POTENTIALLY EXPLOSIVE ATMOSPHERES (HAZARDOUS LOCATIONS)

Suitable for Zone 1, Eex d IIC explosive atmospheres, in accordance with Potentially Explosive Atmospheres Directive 94/9/EC (ATEX)

Suitable for Division 1; Class 1, Groups A, B, C and D; Class II, Groups E, F and G hazardous locations, in accordance with the National Electric Code (NEC), and applicable UL, FM and CSA specifications.

ELECTRICAL CONNECTIONS

18 AWG free leads 18 in (46 cm) long are standard, with a green wire grounded to the case. 72 inch (183 cm) leads are available as R Option, and other lead lengths may be ordered as special configurations. The leads are intended for installation in conduit capable of withstanding possible explosion pressures, and the leads are factory sealed. See Figure 2 below for color codes.

WARNING All field wiring must comply with requirements of the NEC or applicable local or national electrical codes, including wire gauges and insulation temperature ratings. Conduit seals may be required.

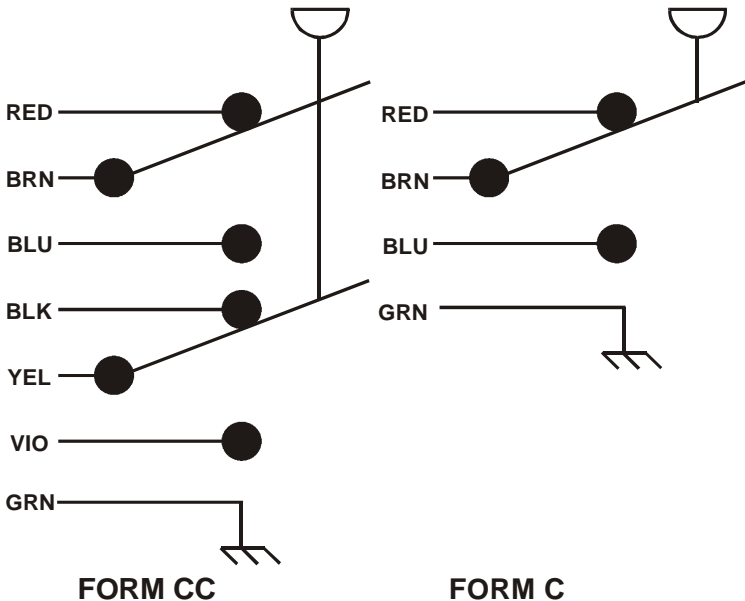

Figure 2. Pressure Switch Schematics Shown at Zero PSIG

NOTE The direction of increasing pressure shown above represents the direction of increasing vacuum on Model 181P.

CHAPTER

3

ADJUSTMENTS and TROUBLESHOOTING

SETPOINT ADJUSTMENT

The factory-set setpoint or adjustable setpoint range is marked on the nameplate of the switch. This section describes the adjustments needed after an Adjustable Pressure Switch has been properly installed.

1. Disconnect the electrical power. Check for multiple circuits.
2. On Model 130P, remove the pressure connection to allow access to the adjustment nut inside the pressure port. On the other models, loosen the screws on the access cover, and swing it to the side.
3. To change the setpoint on Model 130P, use an Allen wrench to rotate the adjustment nut counterclockwise to increase the setpoint, and clockwise to decrease it. It takes approximately 3 to 5 turns to move from one end of the adjustable range to the other (the higher range units require more turns than the lower range units). Check the setpoints per paragraphs 5 and 6 below for precise adjustments.

4. On the other models, the adjustment nut can be rotated by hand or with a small-shafted screwdriver or similar tool inserted into a slot. The range scale is intended to be used only as an approximate guide; it indicates the increasing setpoint on Models 122P, 123P, 132P, and 232P, and decreasing setpoint on Models 131P, 181P, and 231P.
5. To check the increasing setpoint, connect a pressure source and a calibrated pressure gauge or transducer to the pressure port and slowly apply increasing pressure (or vacuum on Model 181P) until the switch actuates. Actuation can be noted by listening to the audible snap of the Belleville spring, or with an ohmmeter across the appropriate free leads.
6. If you want to check the decreasing setpoint, slowly decrease the pressure or vacuum after the switch has actuated and note the value at which the audible snap or an ohmmeter indicates deactuation. Deadband may be calculated if desired by subtracting the decreasing setpoint reading from the increasing setpoint reading.
7. On all models except 130P, replace the cover by swinging it back into position over the adjustment window and tightening the screws until the cover is snug against its gasket. Do not overtighten, as this could damage the gasket.

TROUBLESHOOTING

In-service problems are unlikely, but the following paragraphs suggest ways to verify any problems that might arise:

1. Pressure Switch Leaks

If a leak is suspected, isolate the pressure switch from the rest of the system. Connect the switch and a calibrated pressure gauge downstream from a pressure source and shutoff valve. Apply normal system pressure, isolate the gauge and Pressure Switch from the pressure source with the shutoff valve for at least one minute, and check for leaks as evidenced by a drop in the gauge reading.

If a leak is verified, return the unit for repair. Contact ITT directly, or your local sales representative or distributor (see www.neodyn.com for a contact list).

2. Failure to Switch

If application of pressure or vacuum 10% greater than the adjusted setpoint fails to produce actuation, first check for contamination in the process connection, and verify that the expected pressure is reaching the sensing diaphragm or piston.

If the Belleville spring can be heard to audibly snap, but an ohmmeter indicates no electrical switching, the cause is probably stuck or burned switch contacts, or the switch element has moved away from the position where it was synchronized with the snap action. Return the unit for repair.

If application of pressure or vacuum 10% greater than the adjusted setpoint fails to produce an audible snap of the Belleville spring, there is probably a mechanical failure or binding due to contamination. Return the unit for repair.

3. Calibration Shifts

If it is suspected that the setpoints have shifted, recheck them per paragraphs 5 and 6 of the Setpoint Adjustment section of this chapter on the previous page. If you verify unstable or drifting setpoints, return the unit for repair.

CHAPTER

4

SPECIFICATIONS

This section shows standard specifications and available options.

STANDARD

Interfaces

All models weigh approximately 20 ounces (0.6 kg) each with an aluminum-alloy body.

Conduit Connection: ½" - 14 NPT male

Standard Pressure Port:

122P: ½" - 14 NPT Female

123P: 1½" - 11½ NPT Male

130P: ¼" - 18 NPT Male

131P, 181P, 231P: ½" - 14 NPT Male and ¼" - 18 NPT Female

125P, 132P, 225P, 232P: ¼" - 18 NPT Female

Part Number

The part number contains information about which configurations and options are included in your Adjustable Pressure Switch. To determine this, compare the part number of your unit with Figure 3 on the next page, and the information in the following tables.

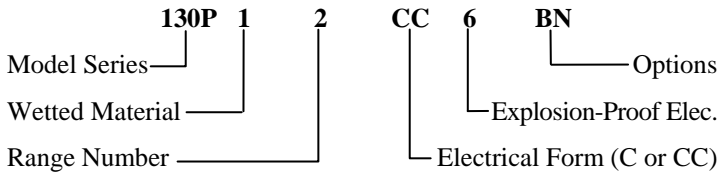

Figure 3. Part Number Breakdown

NOTE Part number format varies for specials.

Wetted Materials

Table 1	
No	Description
1	Aluminum alloy port, teflon-coated polyimide (Kapton) diaphragm and nitrile O-ring (Models 125P, 130P, 131P, 181P)
1	Aluminum alloy port and piston, Teflon seal, and nitrile O-ring (Models 225P and 231P)
4	UNS S31600 CRES port, teflon coated polyimide diaphragm and nitrile O-ring. (Models 125P, 130P, 131P, 132P, 181P)
4	300-series CRES port and piston, Teflon seal, and nitrile O-ring (Models 231P and 232P)
5	UNS S31600 CRES port and diaphragm, heliarc welded (Models 123P and 132P).
6	Hastelloy C port and Tantalum diaphragm, electron-beam welded (Model 132P only)
7	Hastelloy C diaphragm, heliarc welded (Model 132P only)

Wetted Material 8 for Model 122P

“Wetted Material 8” allows various material combinations. The part number of this Model contains a series of 3 numbers following the miscellaneous options; these numbers define the individual wetted materials:

Example: 122P82C6MN443

1st Number (4) is Pressure Port Material:

4	UNS 31600 CRES	8	Monel
5	UNS 31600 CRES*	9	Monel***
7	Hastelloy C**		

2nd Number (4) is Diaphragm Material:

1	Polyimide (Kapton)	7	Hastelloy C
4	UNS 31600 CRES	9	Inconel
6	Tantalum		

3rd Number (3) is O-ring Material:

0	None Required	5	EPR
2	Kalrez	8	Nitrile
3	Viton		

* For welded 316 CRES diaphragm, add 40

** For welded Hastelloy diaphragm, add 70

*** For welded Inconel diaphragm, add 90

Listing Agency Approvals

All models CE Mark
Switch Subassemblies UL, FM, ATEX and CSA listed

Pressure Ratings - Model 130P

All Ranges (1 through 7):

Maximum Operating Pressure 600 psig (41.37 bar)

Proof Pressure 1000 psig (68.95 bar)

Pressure Ratings - Model 131P

All Ranges (2 through 6):

Maximum Operating Pressure 1000 psig (68.95 bar)

Proof Pressure 2000 psig (137.9 bar)

Pressure Ratings - Models 122P and 132P

* See Figure 3 on page 11 for the part number breakdown

Table 2			
Part No	Range No	Max Operating Pressure, psig (bar)	Proof Pressure PSIG (bar)
132P*8*6N	8	1350 (93)	2000 (138)
132P*9*6N	9	1350 (93)	2000 (138)
132P*1*6N	1	5000 (345)	7500 (517)
132P*2*6N	2	5000 (345)	7500 (517)
132P*4*6N	4	5000 (345)	7500 (517)
132P*6*6N	6	6300 (434)	7500 (517)
132P*7*6N	7	6300 (434)	7500 (517)

Pressure Ratings - Model 123P

Table 3			
Part No	Range No	Max Operating Pressure, psig (bar)	Proof Pressure PSIG (bar)
123P*2*6N	2	1350 (93.1)	2000 (138)
123P*4*6N	4	1350 (93.1)	2000 (138)
123P*5*6N	5	3000 (207)	5000 (345)
123P*6*6N	6	3000 (207)	5000 (345)
123P*7*6N	7	3000 (207)	5000 (345)
123P*8*6N	8	3000 (207)	5000 (345)
123P*9*6N	9	3000 (207)	5000 (345)

Pressure Ratings - Model 181P

Range 2: Maximum Operating Pressure 150 psig (10.34 bar).
Proof Pressure 250 psig (17.24 bar).

Pressure Ratings - Model 231P

Table 4			
Part No	Range No	Max Operating Pressure, psig (bar)	Proof Pressure psig (bar)
231P*3*6N	3	4000 (276)	5000 (345)
231P*4*6N	4	4000 (276)	5000 (345)
231P*5*6N	5	6000 (414)	8000 (552)
231P*6*6N	6	6000 (414)	8000 (552)
231P*7*6N	7	8000 (552)	10000 (690)

Pressure Ratings - Model 232P

Table 5			
Part No	Range No	Max Operating Pressure, psig (bar)	Proof Pressure psig (bar)
232P*1*6N	1	5000 (276)	7500 (517)
232P*2*6N	2	6500 (448)	7500 (517)
232P*3*6N	3	6500 (448)	7500 (517)
232P*4*6N	4	10000 (690)	13500 (931)
232P*5*6N	5	10000 (690)	13500 (931)
232P*6*6N	6	12500 (862)	15000 (1034)

Pressure Ratings - Factory-Set Pressure Switches

The following models are similar to Models 132P and 232P, but are factory-set "tamperproof" models and do not have an adjustment cover.

Table 6				
Model No **	Max Operating Hydraulic Pressure, psig (bar)	Max Operating Pneumatic Pressure, psig (bar)	Hydraulic Proof Pressure psig (bar)	Pneumatic Proof Pressure psig (bar)
125P	5000 (276)	3000 (207)	7500 (517)	7500 (517)
225P	5000 (276)	3000 (207)	7500 (517)	7500 (517)
225PP	10000 (690)	5000 (276)	15000 (1034)	7500 (517)

** Contact Neo-Dyn marketing for part number breakdown

Weather Proof Ratings:

Ingress protection IP66

Enclosure type 3, 3R, 3S, 4, 4X, 13 (NEMA)

Temperature Ranges for Pressure Media

Standard (Nitrile O-rings
and wetted materials 5-9);

C Option: -40°C (-40°F) to +121°C (+250°F)

B Option (Viton O-rings): -26°C (-15°F) to +121°C (+250°F)

Electrical and Ambient Temperature Ratings

Minimum ambient temperature is -40 °C (-40 °F), except with
B Option and Kalrez O-rings it is -26°C (-15°F)

Form C6N (SPDT):

11 amp @ 125 or 250 VAC to +75 °C (+167 °F) max, T5;

11 amp @ 125 or 250 VAC to +60 °C (+140 °F) max, T6;

5 amp @ 125 or 250 VAC 5; 5 amp resistive , 3 amp inductive @
28 VDC; .5 amp resistive, .04 amp inductive @ 125 VDC to
+70 °C (+158 °F) max, T6.

Form CC6N (DPDT):

11 amp @ 125 or 250 VAC to +65 °C (+149 °F) max, T4;

11 amp @ 125 or 250 VAC to +45 °C (+113 °F) max, T6;

5 amp @ 125 or 250 VAC; 5 amp resistive , 3 amp inductive @
28 VDC; .5 amp resistive, .04 amp inductive @ 125 VDC to
+70 °C (+158 °F) max, T6.

Form C6MN or CC6MN (SPDT or DPDT with M Option):

1 amp @ 125 VAC to +70 °C (+158 °F) max. T6

OPTIONS

The available options for standard switches are listed below. These options can be combined; every included option will be indicated in the part number of the unit.

Table 7		
Option	Description	Available on Model
A	Epoxy-painted exterior	All
B	Viton O-Ring - Refer to Wetted Materials	All
C	EPR O-Ring - Refer to Wetted Materials	All
E	7/16 - 20 SAE Port	131P, 132P, 232P
G	½ - 14 NPT Female Port	131P, 132P, 232P
H	316 CRES Body	130P, 181P, 231P
M	Gold Electrical Contacts For Extremely Low Current Applications	All
N	CE Mark	All
R	72 inch (183 cm) electrical free leads	All
S	Corrosion-Resistant Steel Diaphragm	130P and 131P, Wetted Material 4 Only
V	¼ - 18 NPT male port	131P
W	CRES exterior screws	125P, 225P
Z	Mounting Bracket Kit	131P, 181P, 231P

WARRANTY INFORMATION

A. Warranty:

ITT Industries (ITT) warrants that at the time of shipment, the products manufactured by ITT Neo-Dyn and sold hereunder, will be free from defects in material and workmanship and will conform to the specifications furnished or approved by ITT.

B. Warranty Adjustment:

If any defect within this warranty appears, the Buyer shall notify ITT immediately.

ITT agrees to repair or furnish a replacement for, but not install, any product which, within one (1) year from the date of shipment by ITT shall, upon test and examination by ITT, prove defective within the above warranty.

No product will be accepted for return or replacement without the written authorization of ITT. Upon such authorization, and in accordance with instructions by ITT, the product will be returned with shipping charges prepaid by the Buyer. Replacements made under this warranty will be shipped prepaid.

C. Exclusion from Warranty:

THE FOREGOING WARRANTY IS IN LIEU OF AND EXCLUDES ALL OTHER EXPRESSED OR IMPLIED WARRANTIES OF MERCHANTABILITY, OR FITNESS, OR OTHERWISE.

Components manufactured by any supplier other than ITT shall bear only the warranty made by the manufacturer of that product, and ITT assumes no responsibility for the performance or reliability of the unit as a whole.

In no event shall ITT be liable for indirect, incidental or consequential damages nor shall the liability of ITT arising in connection with any products sold hereunder (whether such liability arises from a claim based on contract, warranty, tort or otherwise) exceed the actual amount paid by Buyer to ITT for the products delivered hereunder.

The warranty does not extend to any product manufactured by ITT, which has been subject to misuse, neglect, accident, improper installation, or to use in violation of instructions furnished by ITT.

The warranty does not extend to or apply to any unit, which has been repaired or altered at any place other than at ITT's factory or service locations, by persons not expressly approved by ITT.