

NEO-DYN[®]

MODELS 100T AND 100TC
ADJUSTABLE TEMPERATURE SWITCHES,
ENCLOSURE 6N FOR EXPLOSIVE ATMOSPHERES

INSTALLATION AND
OPERATION MANUAL



ITT

Engineered for life

Manual No. 610-0014 Rev D
Neo-Dyn
28150 Industry Drive
Valencia, CA 91355
Tel: (661) 295-4000
Fax: (661) 294-1750
World Wide Web: www.neodyn.com
©Copyright 2002
ITT Industries

Important Information

The product warranty applicable to this ITT Neo-Dyn® instrument is as stated on page 11 of this manual.

Should any after-delivery problems arise, please contact ITT Neo-Dyn's Customer Service using the information above. Our normal business hours are weekdays, 7:00 am to 3:30 PM, Pacific Time.

Before installing this Temperature Switch, become familiar with the installation and adjustment instructions in Chapters 2 and 3.

WARNING **Indicates a hazard which can cause severe personal injury, death, or substantial property damage if the warning is ignored.**

CAUTION Indicates a hazard which will or can cause minor personal injury or property damage if the caution is ignored.

NOTE Indicates additional information about a particular item necessary to the operation of the unit.

SPECIAL CONDITIONS FOR SAFE USE The Electrical Snap Switch Assemblies shall be installed such that the equipment wiring is protected from mechanical damage by the use of metal conduit or a method providing equivalent protection. The equipment wiring must not be subjected to tension or torque. If it is to be terminated within a potentially explosive atmosphere, a suitably certified termination facility must be used.

This document contains proprietary information, which is the property of Neo-Dyn, a unit of ITT Industries. This document may not be reproduced, either in part or in full, without the consent of ITT Industries.

TABLE OF CONTENTS

	PAGE
CHAPTER 1 INTRODUCTION.....	1
OTHER CONFIGURATIONS.....	2
CUSTOMER SERVICE.....	2
CHAPTER 2 INSTALLATION AND OPERATION.....	3
MOUNTING.....	3
PROCESS CONNECTIONS.....	4
PROCESS MEDIA.....	4
ELECTRICAL CONNECTIONS.....	4
POTENTIALLY EXPLOSIVE ATMOSPHERES (HAZARDOUS LOCATIONS).....	5
ALLOWABLE PRESSURES AND TEMPERATURES.....	5
CHAPTER 3 ADJUSTMENTS AND TROUBLESHOOTING .	6
SETPOINT ADJUSTMENT.....	6
TROUBLESHOOTING.....	7
CHAPTER 4 SPECIFICATIONS.....	8
STANDARD.....	8
OPTIONS.....	10
WARRANTY INFORMATION.....	11

CHAPTER

1

INTRODUCTION

The Neo-Dyn® Enclosure 6N Temperature Switches described in this manual are weather and explosion-proof, electromechanical sensing devices designed for a wide range of applications in pneumatic and hydraulic systems up to 1500 psig, and for use in Zone 1 Potentially Explosive Atmospheres (Division 1 hazardous locations). Model 100T has its temperature sensor mounted on its case, while Model 100TC has a remote sensor, mounted at the end of a flexible capillary.

The wetted materials of both models include a welded corrosion-resistant steel (CRES) temperature sensor. Model 100T has a Teflon seal, while Model 100TC has a graphite-filled non-asbestos packing.

Setpoint adjustments are easily made through the adjustable range by turning an adjustment nut located inside the housing.

The standard configuration of these switches will switch up to 11 amp at 125 or 250 VAC, 5 amp resistive at 28 VDC, or 0.5 amp resistive at 125 VDC. When ordered with M Option, the switch is rated for currents to one amp, but its bifurcated gold contacts will reliably switch currents in the milliamper and microampere ranges.

These switches have CE Mark, and they have weatherproof enclosures with IP66 ingress protection and that meet the requirements of NEMA 3, 3R, 3S, 4, 4X and 13. The electrical subassemblies are listed by Underwrites Laboratories, CSA International, Factory Mutual and ATEX.

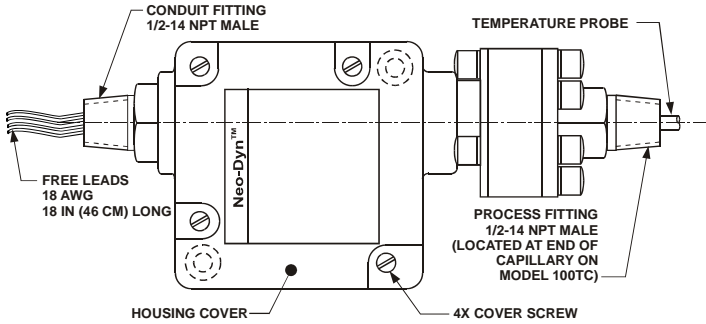

Figure 1: Models 100T and 100TC Enclosure 6N Adjustable Temperature Switches for Explosion Proof Applications

Hidden lines indicate mounting holes under the cover (see page 3).

Chapter 4 on page 8 contains complete specifications.

OTHER CONFIGURATIONS

WARNING The models described in this manual are also available in special and factory-set configurations. For these units, follow the installation and operating instructions herein, except **adhere to the pressure and electrical limits marked on the units.**

CUSTOMER SERVICE

If you have any questions about these Temperature Switches that are not covered in this manual, you can contact Neo-Dyn or our representatives in several ways.

The Neo-Dyn customer service phone number is (661) 295-4000. Our customer service department is open from 7:00 am to 3:30 p.m. Pacific Time.

Our Internet site is www.neodyn.com; it includes lists of sales representatives and distributors.

CHAPTER

2

INSTALLATION AND OPERATION

Installation of these Neo-Dyn® Enclosure 6N temperature switches is straightforward. However, they must be installed by a qualified electrician, in compliance with all local and national electrical codes.

WARNING **Electrical Hazard**

WARNING **Do not make electrical connections while power is on.**

WARNING **Always check for multiple circuits.**

WARNING **Always make sure grounding is adequate.**

MOUNTING

Model 100T can be mounted directly to the process connection if there is no significant vibration and the fluid lines are capable of supporting the weight. It can also be attached to a flat surface, such as a wall or panel, using .250 in. diameter or M6 socket-head cap screws through the mounting holes that are accessed by removing the housing cover; allow .5 in (12.7 mm) screw length above the mounting surface. These holes are located on two corners of a 2.72 inch (6.91 cm) square, or 3.85 inches (9.77 cm) apart on a 45° diagonal. Model 100TC must be mounted by this method, as its remote temperature sensor will not support the housing. Do not overtighten the screws when replacing the cover.

PROCESS CONNECTIONS

The process connections are:

Model 100T: ½” - 14 NPT male standard. The .25 in. (6.4 mm) dia. probe extends 3.0 in. (76 mm) past the end of the pipe thread.

Model 100TC: ½” - 14 NPT male standard. The .38 in. (9.7 mm) dia. probe extends 4.50 in. (114 mm) min. from the end of the pipe thread, and can be extended an additional 9.5 in. (241 mm). After this length adjustment, torque the gland nut in the pipe fitting to 230 ± 20 in-lb (26.0 ± 2.3 newton-meters).

When installing the Temperature Switch, always:

- Make sure that the unit and your system have matching threads.
- Use the wrench flats provided.
- Seal all joints with pipe joint sealing compound.

CAUTION Avoid excessive torque on all threaded connections.

PROCESS MEDIA

Process media must be compatible with the wetted materials listed in Chapter 4 starting on page 9. Compatibility is defined by an “A” rating in the Chemical Resistance Guide for Metals and Alloys, and, as applicable, the Chemical Resistance Guide for Plastics or the Chemical Resistance Guide for Elastomers. All are published by Compass Publications and are available from the National Association of Corrosion Engineers (NACE), Houston, Texas; telephone 281 228-6200.

ELECTRICAL CONNECTIONS

18 AWG free leads, 18 inches (48.3 cm) long are standard. See Figure 2 below for color codes.

WARNING All field wiring must comply with requirements of the NEC or applicable local or national electrical codes, including wire gauges and insulation temperature ratings. Conduit seals may be required.

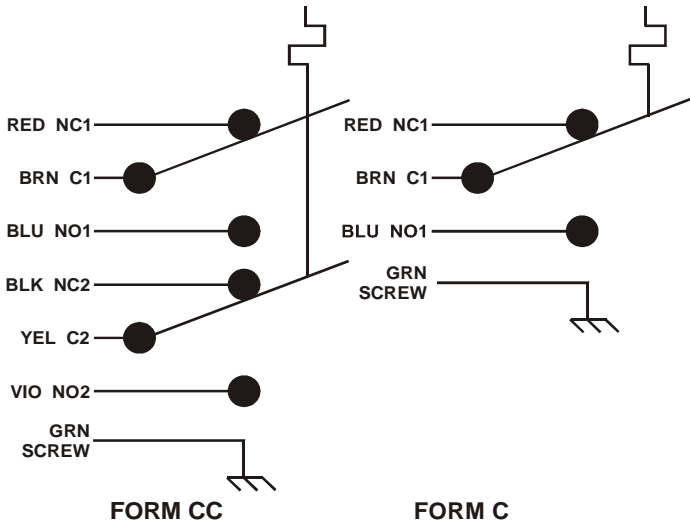

Figure 2. Form C and CC Schematics Shown Below the Decreasing Setpoint

POTENTIALLY EXPLOSIVE ATMOSPHERES (HAZARDOUS LOCATIONS)

Suitable for Zone 1, Eex d IIC explosive atmospheres, in accordance with Potentially Explosive Atmospheres Directive 94/9/EC (ATEX)

Suitable for Division 1; Class 1, Groups A, B, C and D; Class II, Groups E, F and G hazardous locations, in accordance with the National Electric Code (NEC), and applicable UL and CSA specifications.

ALLOWABLE PRESSURES AND TEMPERATURES

***WARNING* Do not exceed the 1500 psig (103.5 bar) Maximum Operating Pressure (System Pressure) in normal operation.**

The 2250 psig (155.1 bar) Proof Pressure is the maximum allowable safety valve setting for the system that will prevent damage to the switch in the event of an overpressure condition. Similarly, the marked Proof Temperature is the maximum temperature the process media could reach in an overtemperature condition without damaging the switch.

CHAPTER

3

ADJUSTMENTS AND TROUBLESHOOTING

The factory-set setpoint or adjustable setpoint range is marked on the nameplate of the switch. This section describes the adjustments needed after an Adjustable Temperature Switch has been properly installed.

SETPOINT ADJUSTMENT

Disconnect the electrical power. Check for multiple circuits.

1. Loosen the screws on the housing cover, and move it aside.
2. Check the setpoints per paragraphs 4 and 5 below for precise adjustments.
3. The adjustment nut can be rotated by hand or with an open-end wrench or similar tool. The range scale indicates the increasing setpoint and is intended to be used only as an approximate guide. Make precise final adjustments using the measurements described in para 4 and 5 below.
4. To check the increasing setpoint of a temperature switch, insert the temperature probe into a fluid bath so that the hex is within 3/8 inch (9.5 mm) of the surface, and also insert a calibrated thermometer into the fluid next to the probe. Slowly increase the temperature of the fluid (try not to exceed 5 °C or 9 °F per minute) until actuation is noted by listening to the audible snap of the Belleville spring, or with an ohmmeter across the appropriate terminals in the terminal block.

5. If you want to check the decreasing setpoint, slowly decrease the temperature after the switch has actuated and note the value at which the audible snap or an ohmmeter indicates deactuation. Deadband may be calculated if desired by subtracting the decreasing setpoint reading from the increasing setpoint reading.

CAUTION 6. Replace the cover by moving it back into position over the top of the housing and tightening the screws until the cover is snug against its gasket. Do not overtighten, as this could damage the gasket.

TROUBLESHOOTING

In-service problems are unlikely, but the following paragraphs suggest ways to verify any problems that might arise:

1. Failure to Switch

If application of temperature 10% greater than the adjusted setpoint fails to produce actuation, first check for contamination in the process connection, and verify that the expected pressure is reaching the sensing diaphragm or piston, or temperature is reaching the temperature probe.

If the Belleville spring can be heard to audibly snap, but an ohmmeter indicates no electrical switching, the cause is probably stuck or burned switch contacts, or the switch element has moved away from the position where it was synchronized with the snap action. Return the unit for repair. Contact ITT directly, or your local sales representative or distributor (see www.neodyn.com for a contact list).

If application of temperature 10% greater than the adjusted setpoint fails to produce an audible snap of the Belleville spring, there is probably a mechanical failure or binding due to contamination. Return the unit for repair.

2. Calibration Shifts

If it is suspected that the setpoints have shifted, recheck them per paragraphs 4 and 5 of the Setpoint Adjustment section of this chapter above. If you verify unstable or drifting setpoints, return the unit for repair.

Wetted Materials

Table 1	
No	Description
3	300-series CRES with Viton seal, except Teflon seal on Range J (Model 100T)
5	300-series CRES with graphite-filled non-asbestos packing (Model 100TC)

Electrical and Ambient Temperature Ratings

Minimum ambient temperature is -40 °C (-40 °F)

Form C6N (SPDT):

11 amp @ 125 or 250 VAC to +75 °C (+167 °F) max, T5;

11 amp @ 125 or 250 VAC to +60 °C (+140 °F) max, T6;

5 amp @ 125 or 250 VAC 5; amp resistive , 3 amp inductive @ 28 VDC; .5 amp resistive, .04 amp inductive @ 125 VDC to +70 °C (+158 °F) max, T6.

Form CC6N (DPDT):

11 amp @ 125 or 250 VAC to +65 °C (+176 °F) max, T4A;

11 amp @ 125 or 250 VAC to +45 °C (+116 °F) max, T6;

5 amp @ 125 or 250 VAC; 5 amp resistive , 3 amp inductive @ 28 VDC; .5 amp resistive, .04 amp inductive @ 125 VDC to +70 °C (+158 °F) max, T6.

Form C6MN or CC6MN (SPDT or DPDT with M Option):

1 amp @ 125 VAC to +70 °C (+158 °F) max, T6.

Listing Agency Approvals

CE Mark

All models

Switch Subassemblies

Underwriters Laboratories
CSA International
Factory Mutual
SIRA (ATEX)

Pressure Ratings

Maximum Operating Pressure: 1500 psig (103.5 bar)

Proof Pressure: 2250 psig (155.1 bar)

Weather Proof Ratings:

Ingress protection IP66

Enclosure type 3, 3R, 3S, 4, 4X, 13 (NEMA)

OPTIONS

The available options for standard switches are listed below. These options can be combined; every included option will be indicated in the part number of the unit.

Table 2		
Option	Description	Available on Model
A	Epoxy-painted exterior	All
M	Gold Electrical Contacts For Extremely Low Current Applications	All
W	Corrosion-resistant steel screws, exterior	All
X	CE mark	All

WARRANTY INFORMATION

A. Warranty:

ITT Industries (ITT) warrants that at the time of shipment, the products manufactured by ITT Neo-Dyn and sold hereunder, will be free from defects in material and workmanship and will conform to the specifications furnished or approved by ITT.

B. Warranty Adjustment:

If any defect within this warranty appears, the Buyer shall notify ITT immediately.

ITT agrees to repair or furnish a replacement for, but not install, any product which, within one (1) year from the date of shipment by ITT shall, upon test and examination by ITT, prove defective within the above warranty.

No product will be accepted for return or replacement without the written authorization of ITT. Upon such authorization, and in accordance with instructions by ITT, the product will be returned with shipping charges prepaid by the Buyer. Replacements made under this warranty will be shipped prepaid.

C. Exclusion from Warranty:

THE FOREGOING WARRANTY IS IN LIEU OF AND EXCLUDES ALL OTHER EXPRESSED OR IMPLIED WARRANTIES OF MERCHANTABILITY, OR FITNESS, OR OTHERWISE.

Components manufactured by any supplier other than ITT shall bear only the warranty made by the manufacturer of that product, and ITT assumes no responsibility for the performance or reliability of the unit as a whole.

In no event shall ITT be liable for indirect, incidental or consequential damages nor shall the liability of ITT arising in connection with any products sold hereunder (whether such liability arises from a claim based on contract, warranty, tort or otherwise) exceed the actual amount paid by Buyer to ITT for the products delivered hereunder.

The warranty does not extend to any product manufactured by ITT, which has been subject to misuse, neglect, accident, improper installation, or to use in violation of instructions furnished by ITT.

The warranty does not extend to or apply to any unit, which has been repaired or altered at any place other than at ITT's factory or service locations, by persons not expressly approved by ITT.