

Neo-Dyn® Series 100P Pressure Switch/Internal Adjustment

Versatile Nega-Rate® Belleville disc spring pressure switch for use in hazardous areas. Applications include pneumatic and low impulse hydraulics up to 3000 psig system pressures. Various wetted material selections make this switch ideal for your specific requirement.

Operating Pressure Data

Adjustable Range Number	Adjustable Set Point Range		Deadband (approximate)	Maximum Recommended System Pressure	Proof Pressure
	Increasing	Decreasing			
1	5 to 75	2.3 to 72.3	2.7	600	1000
2	15 to 150	9 to 144	6	3000	5000
4	50 to 300	36 to 286	14	3000	5000
5	125 to 600	100 to 575	25	3000	5000
7	500 to 1500	440 to 1440	60	3000	5000
8	800 to 2800	675 to 2675	125	3000	5000

All values given in psig.

Standard Specifications

Electrical

Snap action electrical switch listed by Underwriters Laboratories, Inc., Factory Mutual and CSA International

Electrical Connection

¾ NPT female conduit connection with terminal block

Pressure Connection

Wetted Material 1

¼ NPT Female

Wetted Material 4, 5, 7 and 9

½ NPT Female

Temperature Range

Ambient: -40°F to +180°F
(-40°C to +82°C)

Media: -40°F to +300°F
(-40°C to +149°C)

Adjustment

Tool free internal adjustment with range scale

Shipping Weight

Approximately 6 pounds

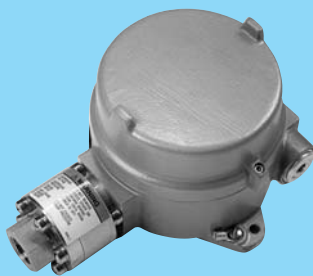

Explosion Proof
(NEMA 4X, 7, 9 and 13)

Ordering Sequence — Select desired option for each category

OPTIONS

Wetted Material

- 1 Aluminum port, Teflon coated polyimide diaphragm, Buna-N O-Ring
- 4 316 stainless steel port, Teflon coated polyimide diaphragm, Buna-N O-Ring
- 5 316 stainless steel port and diaphragm, heliarc welded
- 7 Hastelloy C port and diaphragm, heliarc welded (Except Range 1)
- 9 Monel port and inconel diaphragm, heliarc welded (Except Range 1)

Adjustable Range

- 1 2.3 psig dec. to 75 psig inc. (0.2 bar dec. to 5.2 bar inc.)
- 2 9 psig dec. to 150 psig inc. (0.6 bar dec. to 10.3 bar inc.)
- 4 36 psig dec. to 300 psig inc. (2.5 bar dec. to 20.7 bar inc.)
- 5 100 psig dec. to 600 psig inc. (6.9 bar dec. to 41.4 bar inc.)
- 7 440 psig dec. to 1500 psig inc. (30.3 bar dec. to 103.4 bar inc.)
- 8 675 psig dec. to 2800 psig inc. (46.5 bar dec. to 193.1 bar inc.)

Electrical Form

- C 15 amp 125, 250 or 480 VAC; 2 amp 600 VAC; ⅛ hp 125 VAC; ¼ hp 250 VAC; .5 amp resistive, .04 amp inductive 125 VDC
- CC 11 amp and ¼ hp 125 or 250 VAC; 5 amp resistive, 3 amp inductive 28 VDC; .5 amp resistive 125 VDC
- Z 15 amp 125, 250 or 480 VAC; ¼ hp 125 VAC; ½ hp 250 VAC; 1 amp resistive, .5 amp inductive 125 VDC

Enclosure

- 7 Explosion proof, **CE MARK Underwriters Laboratories, Inc.** listed (File E56677), **CSA International** certified (File LR34146), **Factory Mutual** approved (File J.I.1R5A9.AE) and **DEMKO** approved (File 00ATEX124734X) for Division 1 and 2; Class I, Groups C and D; Class II, Groups E, F and G Hazardous Locations; NEMA type 7 and 9.

Miscellaneous

- A Epoxy paint exterior — extra protection for severe environments
- B Viton O-Ring
- C EPR O-Ring
- E ⅞" - 20 SAE Female Port (wetted material 1 only)
- F Fire fuse — for fire-tested equipment (wetted material 4 & 5 only)
- M Gold electrical contacts for extremely low current applications
- S Stainless steel diaphragm (wetted material 4 only)
- W Stainless steel screws — exterior (Standard with Wetted Materials 4, 5, 7 and 9)

Ordering Procedure

- When factory presetting is desired, stipulate set point, increasing or decreasing
- Insert available option number or letter designation as required

Example

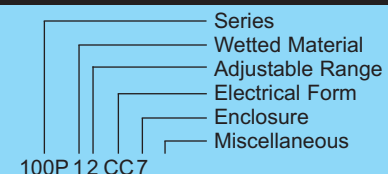

Envelope Dimensions

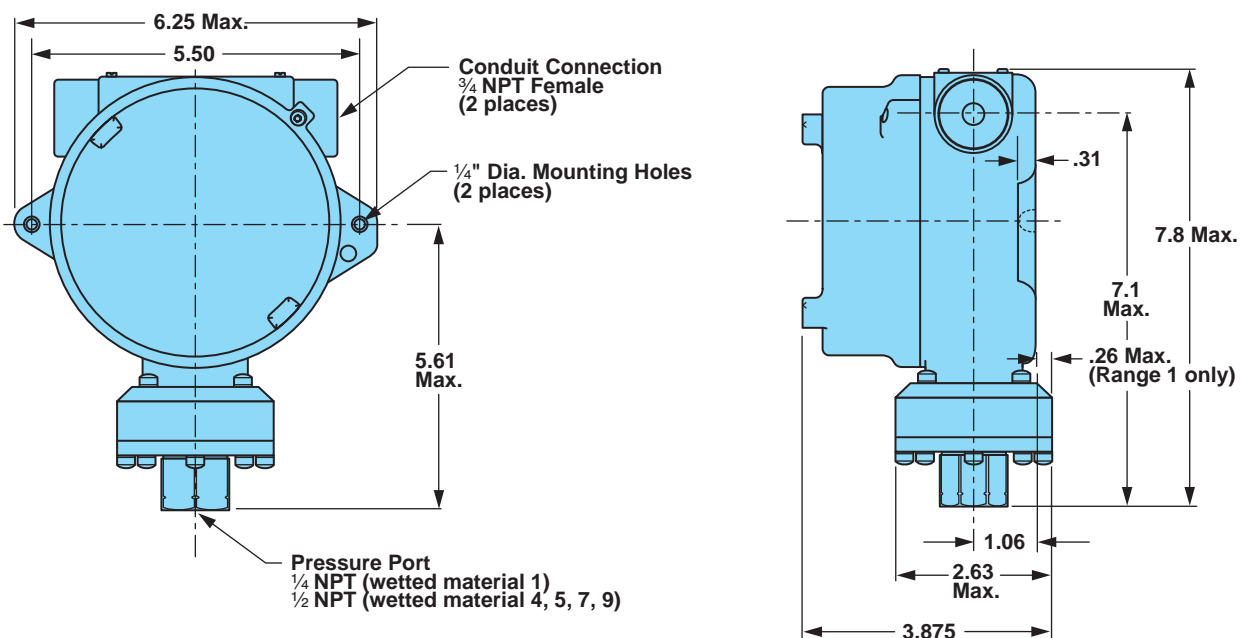

Electrical Form

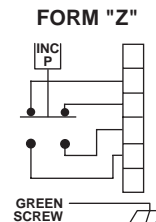
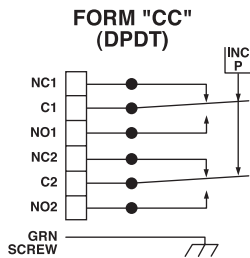
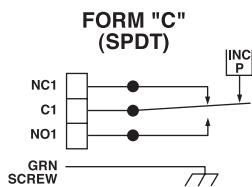

Basic Principles of Design

